

- Large - Black  
Grand - Noir  
Gross - Schwarz  
Largo - Negro
- ▣ Small - White  
Petit - Blanc  
Klein - Weiss  
Pequeño - Blanco
- ⏻ Stand - By  
Attente  
Bereitschaft  
En Espera
- ⏻ Frame or Chassis  
Masse  
Chassis  
Soporte o Chasis
- ⊙ X-Ray Tube  
Tube Radiogène  
Röntgen Röhre  
Tubo de Rayos X
- ⚡ Radiation Filter or Filtration  
Filtre de rayonnement  
Filterung  
Filtración de Radiación

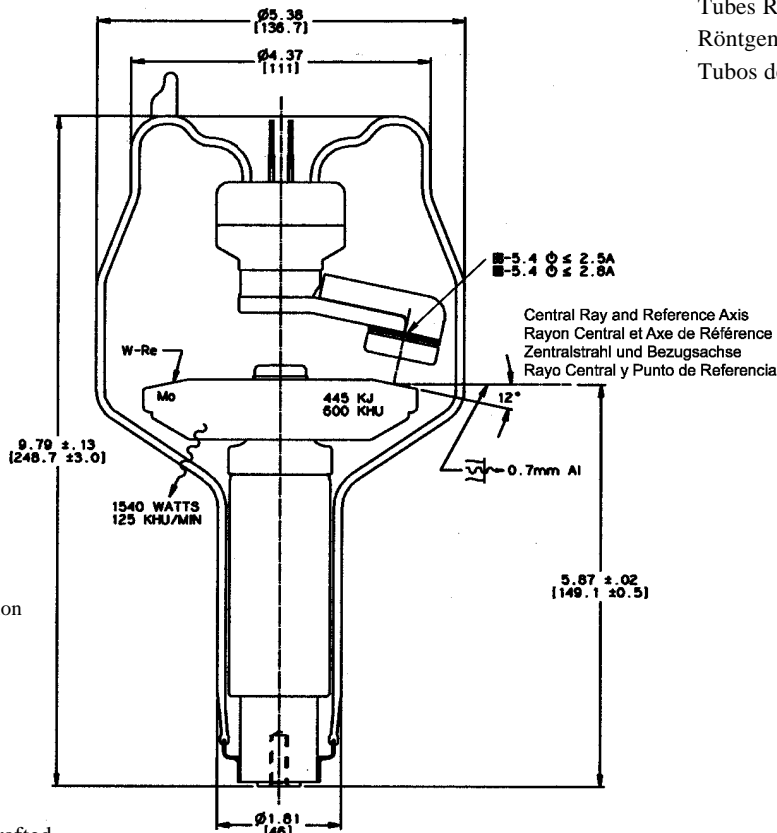

Tubes Radiogènes à Anode Tournante  
 Röntgenröhre mit rotierender Anode  
 Tubos de Rayos - X con Ánodo Giratorio

**X-Ray Coverage:** 17 Degrees from central ray with cutoff of 10 degrees by the anode heel. Covers a 14.1" x 14.1" film at 40" focal-spot-to-film distance. To determine film coverage at other focal-spot-to-film distances, multiply the focal-spot-to-film distance by 0.353 (2x tangent of 10°).

**Couverture de Champ:** L'angle d'ouverture de 17 degrés de part et d'autre du rayon central est limité à 10 degrés par le talon d'anode. Il permet la couverture d'un champ de 35 x 35 cm (14.1" x 14.1") à une distance focale de 100 cm (40"). Pour déterminer le champ couvert à d'autres focales, multipliez la distance focale par 0.353 (tangente de 10° par 2).

**Röntgenstreuung:** 17 Grad vom Zentralstrahl, bei einem Nutzstrahlenkegel von 10 Grad. Bei einem Film-Fokus Abstand von 100 cm (40") beträgt das Strahlenfeld 35 x 35 cm. (14.1" x 14.1") Zur Beurteilung anderer Film-Fokus Abstände: 0.353 (2 x tan 10°) x FFA.

**Haz de Rayos X:** El blanco emisor tiene un ángulo de incidencia de 17 grados en la parte rayo central, separado por una pendiente de 10 grados. Cubre una placa de 14.1" x 14.1" (35 x 35 cm), a una distancia de 40" (100 cm). Para calcular diferentes distancias, multiplique la marca focal y la distancia de la placa por 0.353 (tangente de 10° por 2).

Note: Document originally drafted in the English language.

G-292 - 738250

Product Description	Description du Produit	Produktbeschreibung	Descripcion del Producto
<p>The G292 is a 4.0" (102 mm) 150 kV, 445 kJ (600 kHU) maximum anode heat content, rotating anode insert. This insert is specifically designed for heavy duty general radio-graphic, cineradiographic and fluoro/spot-film procedures. The insert features a 12° rhenium-tungsten facing on molybdenum with a graphite backed target and is available with the following nominal focal spots:</p> <p style="text-align: center;">0.6 - 1.2 IEC 336 (1993)</p> <p>This insert is intended for use in Varian B130 housings. G294 models have grid control capability.</p>	<p>Le tube G292, à anode tournante de 102 mm, (4.0 pouces), 150 kV, avec une capacité calorifique maximale de 445 kJ (600 kUC) est à usage spécifique pour la radiographie de grande puissance, radiocinéma et pour la radio-fluorographie. L'angle de l'anode en Molybdène traitée, Rhénium - Tungstène, recouverte de graphite, est de 12°. Il est disponible avec les foyers suivantes:</p> <p style="text-align: center;">0,6 - 1,2 CEI 336 (1993)</p> <p>Ce tube est essentiellement destiné à être employé dans les gaines Varian des séries B130. Les modèles G294 ont une fonction de commande de grille.</p>	<p>Die G292 ist eine 4.0" (102 mm) Doppelfokus Drehanoden-Röntgenröhre, mit einer Anoden Wärmespeicherkapazität von 445 kJ (600 kHU) und einer max. Spannungsfestigkeit von 150 kV. Die Röhre wurde für stark frequentierte Aufnahmeplätze und für den Durchleuchtungs-kino-bzw. Zielgerätebetrieb (1mm FFA) ausgelegt. Der rückseitig mit Graphit beschichtete Rhenium-Wolfram- und Molybdän Anodenteller besitzt einen Winkel von 12°. Folgende Brennfleckkombination sind lieferbar:</p> <p style="text-align: center;">0.6 - 1.2 IEC 336 (1993)</p> <p>Die Röntgenröhre ist für den Einbau in die Varian Strahlerhauben B130 vorgesehen. Modell G294 ist mit einer Gittersteuerungsfunktion ausgestattet.</p>	<p>El G292 es un tubo de ánodo giratorio de 102 mm (4.0"), 150 kV, 445 kJ (600 kUC) diseñado específicamente para procedimientos generales de alto volumen en radiografía, cineradiográfica y fluoroscopia. El blanco emisor es una combinación de renio, tungsteno y molibdeno con grafito en la parte posterior con un rayo central de 12 grados. Disponible con las siguientes combina de marcas focales:</p> <p style="text-align: center;">0.6- 1.2 IEC 336 (1993)</p> <p>Este tubo es diseñado, para uso en los encajes Varian de la serie B130. El modelo G294 tiene capacidad para de Rejillas controlar los electrones.</p>

Manufactured by Varian Medical Systems  
Fabrique par Varian Medical Systems  
Hergestellt von Varian Medical Systems  
Fabricado por Varian Medical Systems

Specifications subject to change without notice.  
Spécifications susceptibles d'être modifiées sans préavis.  
Technische Daten ohne Gewähr.  
Especificaciones sujetas a cambio sin previo aviso.

### 3 Ø Constant Potential

Abaques de Charge pour Pose Unique CEI 613/1989  
Brennfleck - Belastungskurven IEC 613/1989  
Diagramas de Exposición Radiográfica IEC 613/1989

#### 50 Hz

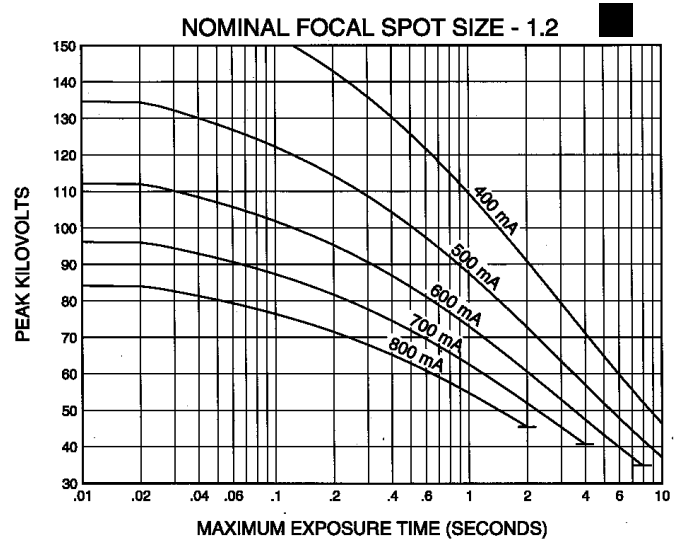
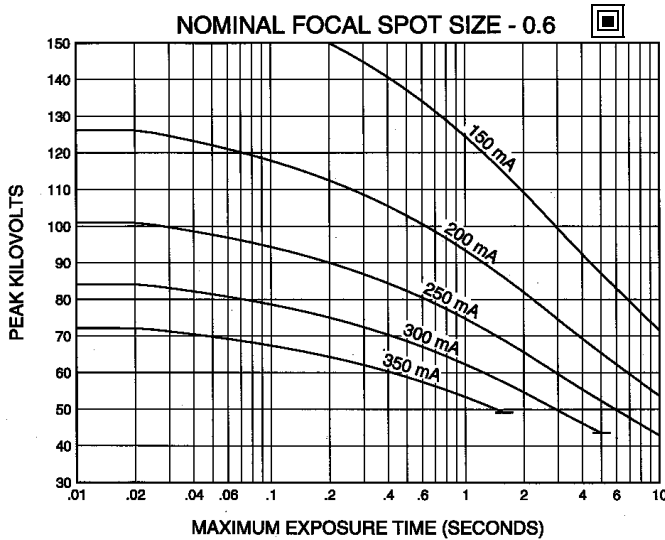

#### 60 Hz

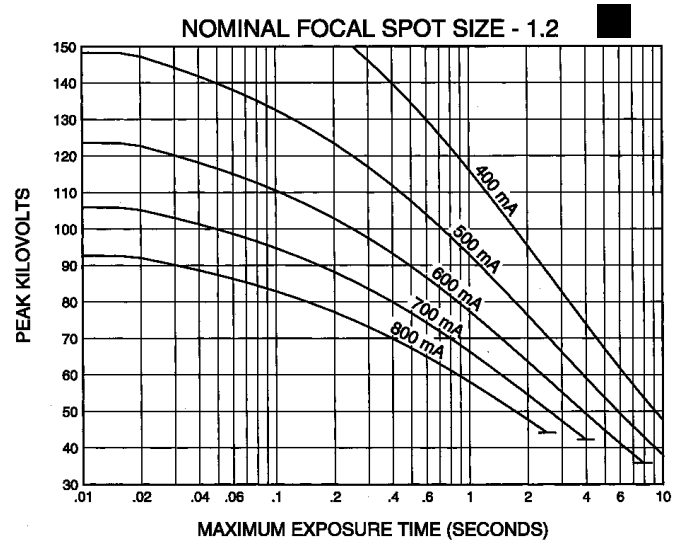
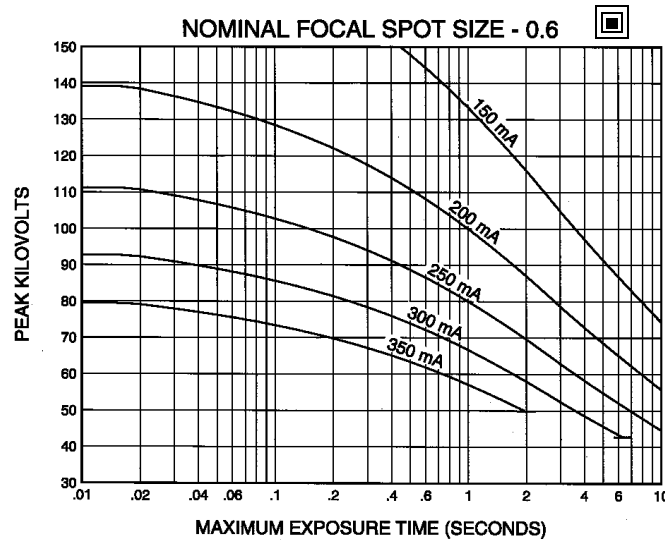

Nominal anode input power for the anode heat content 40%. IEC 613/1989

Puissance calorifique nominale de l'anode: 40%, CEI 613/1989

Thermische Anoden bezugsleistung für eine speicherung von 40%. IEC 613/1989

Aproximadamente el Poder de Penetración Para Obtener Unalmacenaje de Calor Del Anodo de 40%. IEC 613/1989

### 3 Ø Constant Potential

Abaques de Charge pour Pose Unique CEI 613/1989  
Brennfleck - Belastungskurven IEC 613/1989  
Diagramas de Exposición Radiográfica IEC 613/1989

#### 150 Hz

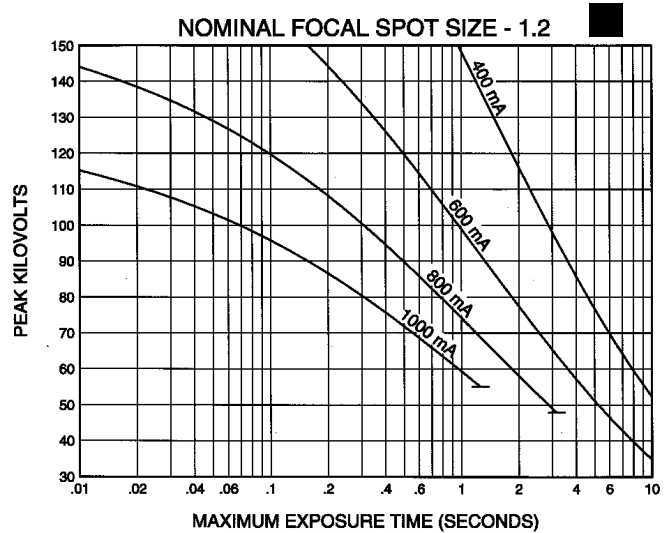
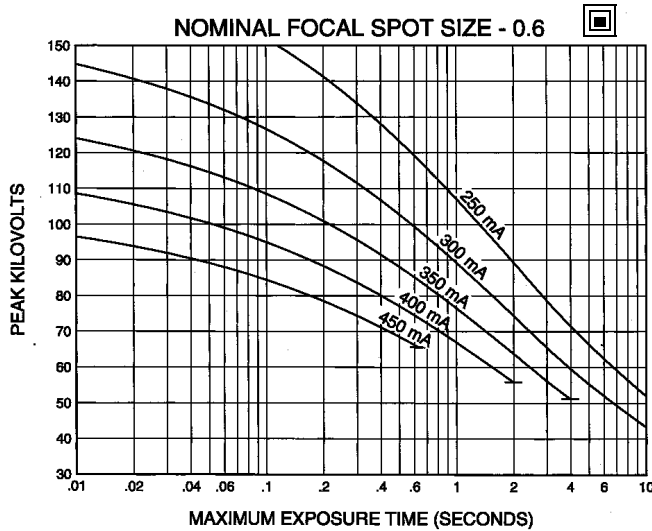

#### 180 Hz

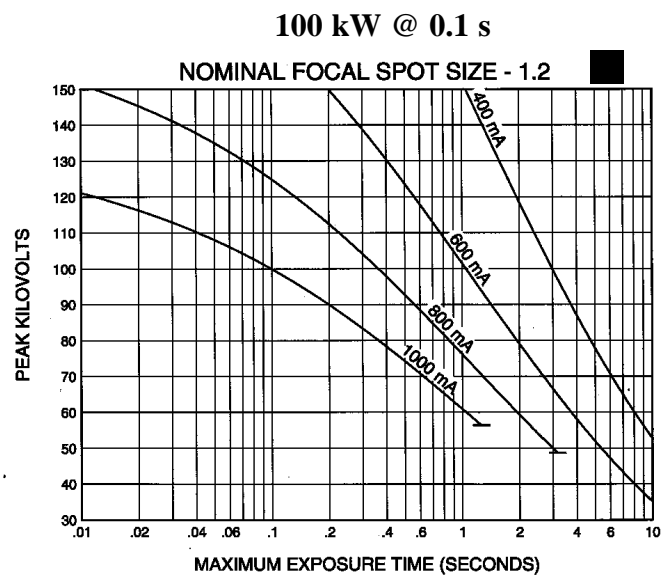
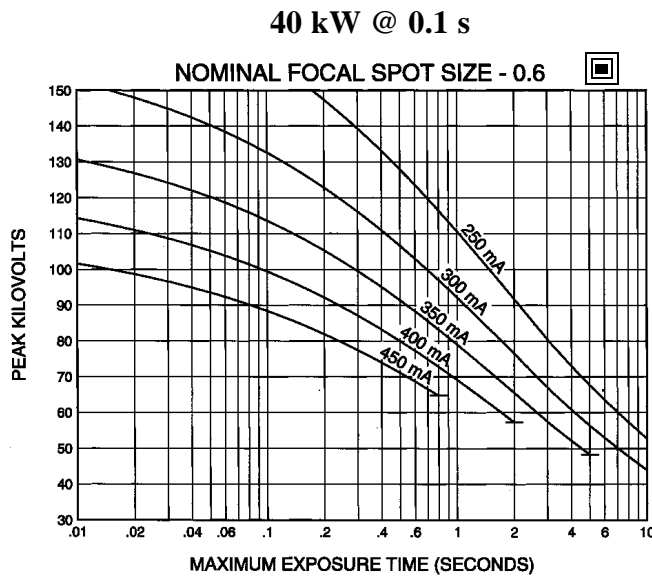

Nominal anode input power for the anode heat content 40%. IEC 613/1989

Puissance calorifique nominale de l'anode: 40%, CEI 613/1989

Thermische Anoden bezugsleistung für eine speicherung von 40%. IEC 613/1989

Aproximadamente el Poder de Penetración Para Obtener Unalmacenaje de Calor Del Anodo de 40%. IEC 613/1989

## CINERADIOGRAPHIC RATINGS

### HOW TO USE CINERADIOGRAPHIC CHARTS

**General:** With the Cineradiographic rating chart we can determine the maximum allowable kW of the Cine pulse, or with a given kW determine maximum time in seconds the Cine run can progress.

The Most common way of using the charts is to determine maximum time of any expected Cine run and maximum duty factor. With a known duty factor and Cine run time the kW can easily be determined.

#### Definition of Terms

**Time in seconds:** Total time of one Cine run, usually 5 to 12 seconds.

**Duty Factor in Percent (DF%):** Actual time during one second the x-ray tube is producing x-rays. If we select a 5 msec pulse width and 50 exposures per second the x-ray tube will be producing x-rays for a total of 250 msec each second or 25% of the time. The higher the DF number, the more load placed on the x-ray tube.

**Peak Pulse Power:** Peak energy in watts of any one Cine Pulse. Can be any combination of kV and mA allowed by Radiographic and Filament Emission curves.

Example: 80 kV at 400 mA equals

$$80,000 \text{ V} \times 0.4 \text{ A} = 32,000 \text{ W} \text{ or } 32 \text{ kW}$$

#### USING THE CINE RATING CHARTS:

G292 150/160 Hz 3 Phase 1.2 Focal Spot

**Example:** Determine maximum kW allowed with the following known factors:  
Maximum Pulse Width ..... 5 msec  
Exposures per Second ..... 50  
Maximum Cine Run Time ... 10 seconds

#### Calculate Duty Factor: (DF%)

$$DF\% = \frac{\text{Pulse Width (msec)} \times \text{Frames per Second}}{10}$$

$$DF\% = \frac{5 \text{ msec} \times 50 \text{ exp/sec}}{10} = \frac{250}{10} = 25\%$$

Refer to Rating Chart G292 150/180 Hz 3 Phase 1.2 Focal Spot:

At bottom of chart find 10 second line. Move vertically to intersection with 25% DF curve. Make a horizontal reference to left side of rating chart and note kW rating of 46 kW.

We now know each pulse during the cine run can have a maximum rating of 46 kW under conditions given in example.

kW = kV x mA. The kW of the exposure can be any combination of mA and kW allowed by the Radiographic and Filament Emission Charts.

The Cine rating charts are usable to 100% anode heat storage. The start of Cine run should be below 70% and heat storage. Exceeding 100% anode heat storage will cause anode track erosion with high risk of tube destruction.

**3 Ø Constant Potential** 

Abaques de Radiocinéma CEI 613/1989  
Belastungskurven für den Kinogrtrieb IEC 613/1989  
Diagramas de Exposición Cineradiográfica IEC 613/1989

**50Hz**

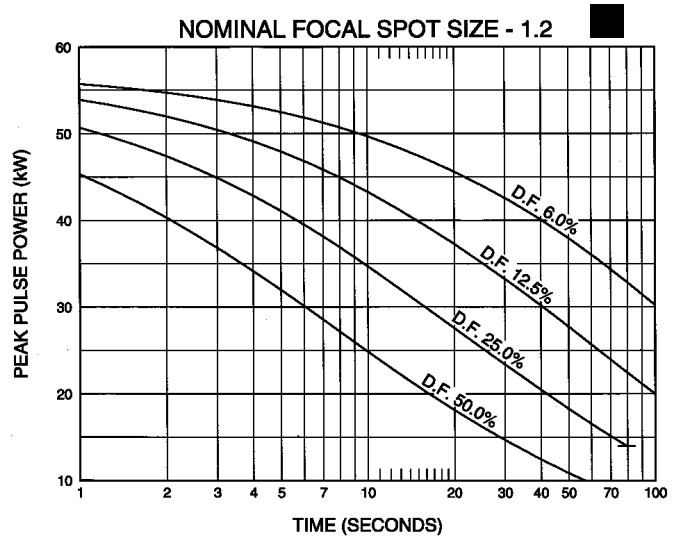
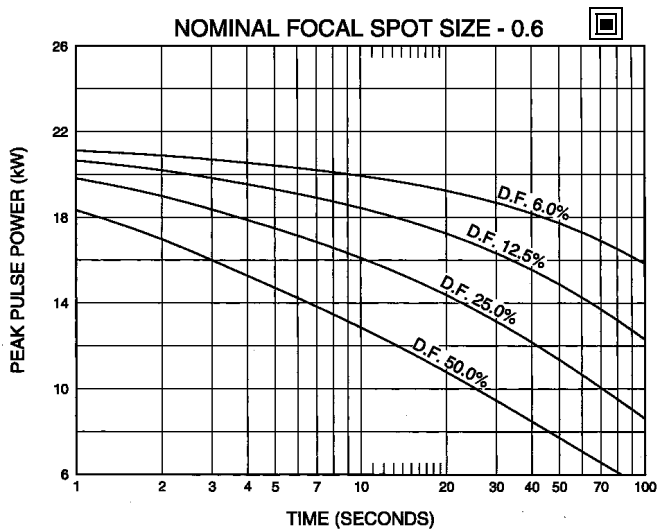

**150Hz**

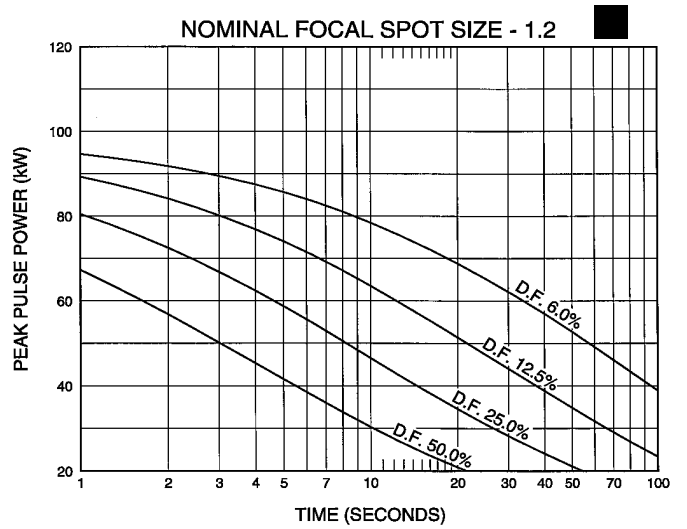
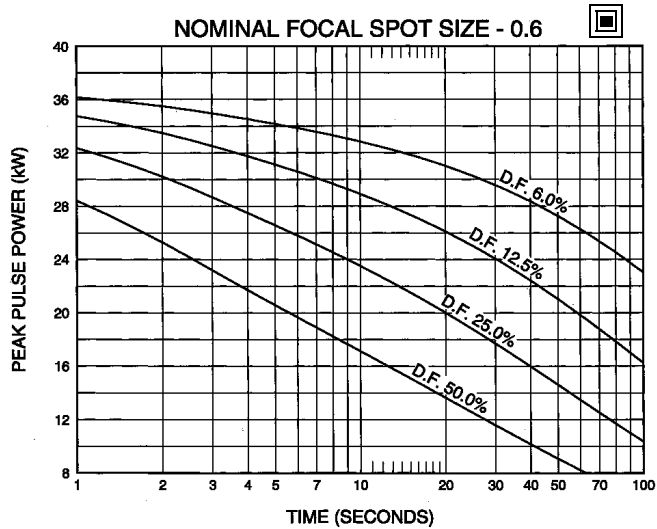

Nominal anode input power for the anode heat content 70%. IEC 613/1989

Puissance calorifique nominale de l'anode: 70%, CEI 613/1989

Thermische Anoden bezugsleistung für eine speicherung von 70%. IEC 613/1989

Aproximadamente el Poder de Penetracion Para Obtener Unalmacenaje de Calor Del Anodo de 70%. IEC 613/1989

## ANGIOGRAPHIC RATINGS

### HOW TO USE ANGIOGRAPHIC CHARTS

**General:** Serial Radiography puts a severe demand on the x-ray tube due to the large number of exposures made in rapid succession. Intervals between exposures are fixed and so short that it is not possible for the anode track to cool to any extent during the exposure series. Therefore, the temperature of the anode track increases from exposure to exposure. The kW values used in the angiographic charts have been determined to prevent damage to the anode. The angiographic rating charts are usable to 100% anode heat storage. Exceeding 100% anode heat storage will cause anode track erosion with high risk of tube destruction.

#### Definition of Terms

**Number of Exposures in Series:** The number of exposures made in succession or the number of exposures made during one contrast injection.

**Exposure Rate:** The number of exposures made per second. For a series of exposures where the exposure rate changes, it must be assumed that all exposures will be made at the maximum rate. For example, if during a series 10 exposures will occur at one per second and 30 exposures at 4 per second, use the kW ratings in the 40 exposure column at 4 per second rate.

**Exposure Time:** Time in seconds of each exposure.

#### USING THE CHARTS:

##### Select Correct Chart:

50/60 or 150/180 Hz

0.6 or 1.2 Focal Spot

**Note:** 150/180 Hz rotor speed recommended for all angiography.

**Determine the number of exposures in Series:** With cut film angiography the number of exposures are known, however in Digital Angiography the number of exposures commonly are not known. When determining the number of exposures, assume worst case or past history.

**Note:** Most angiographic x-ray tubes fail from underestimating the number of exposures made in a series.

**Determine kW of each exposure in Series:** Referring to chart —find block under “Number of Exposures in Series” that is greater than or equal to expected number of exposures in Series. On left side directly opposite this block under “Exposure Rate per Second” column, select maximum rate per second that will be used for the exposure series. At the intersection of exposure rate and exposure time in seconds, find maximum kW allowed for each exposure.

**kW = pkV x mA:** The kW of the exposure can be any combination of mA and pkV allowed by the Radiographic and Filament Emission charts.

For Example: 80 pkV and 500 mA = 40 kW

**Example:** From chart G292 150/180 Hz 3 Phase 1.2 Focal Spot, determine kW allowed with following known factors.  
 Maximum number of exposures .....40  
 Exposure time .050 second (50 milliseconds)  
 Maximum Exposure per second .....4

From chart find 40 exposure block. On left side directly opposite this block under “Exposure Rate per Second” column, select 4 exposures per second. Find .050 seconds at top of chart. At intersection of exposure rate line and exposure time, find 50.2 kW.

0.6 Focal Spot 3Ø 12 Degrees 50/60 Hz  
0.6 Dimension Focale 3Ø 12 Degrés 50/60 Hz  
0.6 Brennpunkt 3Ø 12 Grad 50/60 Hz  
0.6 De Marcas Focales 3Ø 12 Grados 50/60 Hz

Caractéristiques Pour L'Angiographie CEI 613/1989  
Angiographische Nennleistungen IEC 613/1989  
Gradaciones Angiografica IEC 613/1989

EXPOSURE RATE PER SECOND	TUBE LOAD (kW) AS A FUNCTION OF THE EXPOSURE TIME (SEC.) OF THE INDIVIDUAL RADIOGRAPHS OF THE SERIES															NUMBER OF EXPOSURES IN SERIES
	0.010	0.020	0.030	0.040	0.050	0.060	0.080	0.100	0.120	0.140	0.160	0.180	0.200	0.225	0.250	
1	21.3	21.1	20.6	20.2	19.8	19.5	18.8	18.3	17.8	17.3	16.9	16.5	16.1	15.7	15.3	10
2	21.2	20.9	20.4	19.9	19.4	19.0	18.3	17.7	17.1	16.5	16.0	15.6	15.2	14.7	14.2	
3	21.2	20.8	20.2	19.7	19.2	18.7	17.9	17.2	16.6	16.0	15.5	15.0				
4	21.1	20.7	20.1	19.5	19.0	18.5	17.7	16.9	16.3	15.7						
8	21.0	20.4	19.7	19.0	18.4	17.9										
15	20.8	20.1	19.3	18.5												
30	20.5	19.6														
1	21.2	20.8	20.2	19.7	19.2	18.8	18.0	17.3	16.7	16.1	15.6	15.1	14.7	14.2	13.7	20
2	21.0	20.6	19.9	19.3	18.7	18.2	17.3	16.5	15.8	15.1	14.6	14.0	13.5	13.0	12.5	
3	20.9	20.4	19.6	18.9	18.3	17.7	16.8	15.9	15.1	14.4	13.8	13.2				
4	20.9	20.2	19.4	18.6	18.0	17.4	16.3	15.4	14.6	13.9						
8	20.6	19.8	18.8	17.9	17.2	16.5										
15	20.4	19.3	18.2	17.2												
30	20.0	18.6														
1	21.0	20.4	19.6	19.0	18.3	17.8	16.8	15.9	15.2	14.5	13.9	13.3	12.8	12.2	11.7	40
2	20.8	20.1	19.2	18.4	17.7	17.1	16.0	15.0	14.2	13.4	12.8	12.2	11.7	11.0	10.5	
3	20.6	19.8	18.8	18.0	17.2	16.5	15.3	14.3	13.4	12.7	12.0	11.4				
4	20.5	19.6	18.5	17.6	16.8	16.1	14.8	13.7	12.8	12.0						
8	20.1	18.9	17.6	16.6	15.6	14.8										
15	19.7	18.2	16.7	15.5												
30	19.2	17.3														
1	20.8	20.0	19.1	18.3	17.6	16.9	15.8	14.8	14.0	13.2	12.6	12.0	11.4	10.8	10.0	60
2	20.6	19.7	18.6	17.7	16.9	16.2	15.0	13.9	13.0	12.2	11.6	10.9	10.4	9.8	9.2	
3	20.4	19.4	18.2	17.3	16.4	15.6	14.3	13.2	12.3	11.5	10.8	10.2				
4	20.3	19.1	17.9	16.9	16.0	15.1	13.8	12.6	11.7	10.9						
8	19.8	18.3	16.9	15.7	14.6	13.7										
15	19.3	17.4	15.8	14.4												
30	18.6	16.4														
1	20.6	19.7	18.6	17.7	16.9	16.2	15.0	13.9	13.0	12.2	11.5	10.4	9.4	8.3	7.5	80
2	20.4	19.3	18.1	17.1	16.3	15.5	14.1	13.0	12.1	11.3	10.6	10.0	9.4	8.3	7.5	
3	20.2	19.0	17.7	16.7	15.7	14.9	13.5	12.4	11.4	10.6	9.9	9.3				
4	20.0	18.7	17.4	16.2	15.3	14.4	13.0	11.8	10.8	10.0						
8	19.5	17.8	16.3	15.0	13.9	13.0										
15	18.9	16.8	15.1	13.6												
30	18.1	15.6														
1	20.4	19.3	18.2	17.2	16.3	15.5	14.2	13.1	12.2	10.7	9.4	8.3	7.5	6.7	6.0	100
2	20.2	18.9	17.7	16.6	15.7	14.8	13.4	12.3	11.3	10.5	9.4	8.3	7.5	6.7	6.0	
3	20.0	18.6	17.3	16.1	15.1	14.3	12.8	11.6	10.7	9.9	9.2	8.3				
4	19.8	18.3	16.9	15.7	14.7	13.8	12.3	11.1	10.1	9.3						
8	19.3	17.4	15.8	14.4	13.3	12.3										
15	18.6	16.4	14.5	13.0												
30	17.7	15.0														
1	19.9	18.5	17.2	16.0	15.0	14.1	12.5	10.0	8.3	7.1	6.2	5.6	5.0	4.4	4.0	150
2	19.7	18.2	16.7	15.4	14.4	13.5	12.0	10.0	8.3	7.1	6.2	5.6	5.0	4.4	4.0	
3	19.5	17.8	16.3	15.0	13.9	12.9	11.4	10.0	8.3	7.1	6.2	5.6				
4	19.3	17.5	15.9	14.6	13.4	12.5	10.9	9.8	8.3	7.1						
8	18.8	16.6	14.8	13.3	12.1	11.1										
15	18.0	15.4	13.4	11.9												
30	16.9	13.9														

**Note:**

1. (kW) of Exposure Equals mA x kV.  
For Example: 70 kV x 300 mA = 21 kW.  
2. Exposures less than .010 seconds will have a kW rating same as .010 seconds.

**Remarque:**

1. (kW) en exposition égale kV x mA.  
Par exemple: 70 kV x 300 mA = 21 kW.  
2. Les expositions inférieures à 0.010 sec. ont les mêmes valeurs en kW que celles de 0.010 sec.

**Anmerkungen:**

1. (kW) der Belichtung ist gleich mA x kV.  
Zum Beispiel: 70 kV x 300 mA = 21 kW.  
2. Belichtungen von weniger als .010 Sekunden haben die gleichen kW Werte wie die von .010 Sekunden.

**Nota:**

1. (kW) De exposición se calcula multiplicando mA x kV-porejemplo: 70 kV x 300 mA = 21 kW.  
2. Para Exposiciones de Menos de .010 segundos, el resultado en (kW) sería lo mismo que el de .010 segundos.

Nominal anode input power for the anode heat content 70%. IEC 613/1989

Puissance calorifique nominale de l'anode: 70%, CEI 613/1989

Thermische Anoden bezugsleistung für eine speicherung von 70%. IEC 613/1989

Aproximadamente el Poder de Penetracion Para Obtener Unalmacenaje de Calor Del Anode de 70%. IEC 613/1989

1.2 Focal Spot 3Ø 12 Degrees 50/60 Hz  
1.2 Dimension Focale 3Ø 12 Degrés 50/60 Hz  
1.2 Brennpunkt 3Ø 12 Grad 50/60 Hz  
1.2 De Marcas Focales 3Ø 12 Grados 50/60 Hz

Caractéristiques Pour L'Angiographie CEI 613/1989  
Angiographische Nennleistungen IEC 613/1989  
Gradaciones Angiografica IEC 613/1989

EXPOSURE RATE PER SECOND	TUBE LOAD (kW) AS A FUNCTION OF THE EXPOSURE TIME (SEC.) OF THE INDIVIDUAL RADIOGRAPHS OF THE SERIES															NUMBER OF EXPOSURES IN SERIES
	0.010	0.020	0.030	0.040	0.050	0.060	0.080	0.100	0.120	0.140	0.160	0.180	0.200	0.225	0.250	
1	56.2	55.0	53.0	51.2	49.7	48.2	45.7	43.6	41.7	39.9	38.4	37.0	35.7	34.2	32.8	10
2	56.0	54.5	52.4	50.4	48.7	47.2	44.4	42.1	40.1	38.2	36.6	35.1	33.7	32.2	30.8	
3	55.8	54.2	51.9	49.8	48.0	46.4	43.5	41.1	38.9	37.0	35.3	33.8	---	---	---	
4	55.6	53.9	51.4	49.3	47.4	45.7	42.7	40.2	38.0	36.0	---	---	---	---	---	
8	55.1	52.9	50.2	47.8	45.7	43.8	---	---	---	---	---	---	---	---	---	
15	54.5	51.8	48.7	46.0	---	---	---	---	---	---	---	---	---	---	---	
30	53.6	50.2	---	---	---	---	---	---	---	---	---	---	---	---	---	
1	55.3	53.2	50.6	48.3	46.2	44.4	41.2	38.5	36.2	34.2	32.4	30.8	29.4	27.7	26.3	20
2	54.9	52.5	49.5	47.0	44.8	42.8	39.4	36.6	34.1	32.0	30.2	28.6	27.1	25.5	24.1	
3	54.6	51.9	48.9	46.2	43.8	41.8	38.2	35.3	32.8	30.7	28.9	27.2	---	---	---	
4	54.3	51.5	48.3	45.5	43.1	40.9	37.3	34.3	31.8	29.7	---	---	---	---	---	
8	53.6	50.2	46.6	43.5	40.9	38.6	---	---	---	---	---	---	---	---	---	
15	52.7	48.7	44.6	41.2	---	---	---	---	---	---	---	---	---	---	---	
30	51.4	46.5	---	---	---	---	---	---	---	---	---	---	---	---	---	
1	53.8	50.5	47.0	44.0	41.4	39.1	35.3	32.2	29.7	26.8	23.4	20.8	18.8	16.7	15.0	40
2	53.1	49.3	45.5	42.2	39.5	37.1	33.1	30.0	27.4	25.3	23.4	20.8	18.8	16.7	15.0	
3	52.6	48.5	44.5	41.1	38.2	35.7	31.7	28.5	26.0	23.8	22.0	20.5	---	---	---	
4	52.3	47.9	43.7	40.2	37.3	34.8	30.7	27.5	25.0	22.9	---	---	---	---	---	
8	51.3	46.3	41.7	37.9	34.8	32.2	---	---	---	---	---	---	---	---	---	
15	50.1	44.3	39.3	35.4	---	---	---	---	---	---	---	---	---	---	---	
30	48.3	41.6	---	---	---	---	---	---	---	---	---	---	---	---	---	
1	52.5	48.2	44.1	40.6	37.7	35.3	31.2	25.0	20.8	17.9	15.6	13.9	12.5	11.1	10.0	60
2	51.7	46.9	42.5	38.8	35.8	33.2	29.1	25.0	20.8	17.9	15.6	13.9	12.5	11.1	10.0	
3	51.1	46.0	41.3	37.5	34.4	31.8	27.7	24.5	20.8	17.9	15.6	13.9	---	---	---	
4	50.6	45.2	40.4	36.5	33.4	30.7	26.6	23.5	20.8	17.9	---	---	---	---	---	
8	49.4	43.3	38.1	34.1	30.8	28.2	---	---	---	---	---	---	---	---	---	
15	48.0	41.2	35.7	31.5	---	---	---	---	---	---	---	---	---	---	---	
30	45.9	38.3	---	---	---	---	---	---	---	---	---	---	---	---	---	
1	51.3	46.2	41.6	37.9	34.8	31.2	23.4	18.8	15.6	13.4	11.7	10.4	9.4	8.3	7.5	80
2	50.4	44.9	40.0	36.1	32.9	30.3	23.4	18.8	15.6	13.4	11.7	10.4	9.4	8.3	7.5	
3	49.8	43.8	38.8	34.8	31.5	28.9	23.4	18.8	15.6	13.4	11.7	10.4	---	---	---	
4	49.2	43.0	37.8	33.7	30.5	27.8	23.4	18.8	15.6	13.4	---	---	---	---	---	
8	47.8	40.8	35.3	31.1	27.9	25.2	---	---	---	---	---	---	---	---	---	
15	46.2	38.6	32.9	28.6	---	---	---	---	---	---	---	---	---	---	---	
30	44.0	35.7	---	---	---	---	---	---	---	---	---	---	---	---	---	
1	50.1	44.4	39.4	35.5	30.0	25.0	18.8	15.0	12.5	10.7	9.4	8.3	7.5	6.7	6.0	100
2	49.2	43.1	37.8	33.8	30.0	25.0	18.8	15.0	12.5	10.7	9.4	8.3	7.5	6.7	6.0	
3	48.5	42.0	36.6	32.5	29.2	25.0	18.8	15.0	12.5	10.7	9.4	8.3	---	---	---	
4	48.0	41.1	35.6	31.5	28.2	25.0	18.8	15.0	12.5	10.7	---	---	---	---	---	
8	46.3	38.8	33.0	28.8	25.6	23.0	---	---	---	---	---	---	---	---	---	
15	44.7	36.5	30.6	26.4	---	---	---	---	---	---	---	---	---	---	---	
30	42.4	33.5	---	---	---	---	---	---	---	---	---	---	---	---	---	
1	47.5	40.5	33.3	25.0	20.0	16.7	12.5	10.0	8.3	7.1	6.2	5.6	5.0	4.4	4.0	150
2	46.6	39.2	33.3	25.0	20.0	16.7	12.5	10.0	8.3	7.1	6.2	5.6	5.0	4.4	4.0	
3	45.9	38.2	32.4	25.0	20.0	16.7	12.5	10.0	8.3	7.1	6.2	5.6	---	---	---	
4	45.3	37.3	31.5	25.0	20.0	16.7	12.5	10.0	8.3	7.1	---	---	---	---	---	
8	43.4	34.8	28.9	24.6	20.0	16.7	---	---	---	---	---	---	---	---	---	
15	41.4	32.4	26.4	22.3	---	---	---	---	---	---	---	---	---	---	---	
30	39.0	29.5	---	---	---	---	---	---	---	---	---	---	---	---	---	

**Note:**  
1. (kW) of Exposure Equals mA x kV.  
For Example: 70 kV x 300 mA = 21 kW.  
2. Exposures less than .010 seconds will have a kW rating same as .010 seconds.

**Remarque:**  
1. (kW) en exposition égale kV x mA.  
Par exemple: 70 kV x 300 mA = 21 kW.  
2. Les expositions inférieures à 0.010 sec. ont les mêmes valeurs en kW que celles de 0.010 sec.

**Anmerkungen:**  
1. (kW) der Belichtung ist gleich mA x kV.  
Zum Beispiel: 70 kV x 300 mA = 21 kW.  
2. Belichtungen von weniger als .010 Sekunden haben die gleichen kW Werte wie die von .010 Sekunden.

**Nota:**  
1. (kW) De exposición se calcula multiplicando mA x kV-porejemplo: 70 kV x 300 mA = 21 kW.  
2. Para Exposición de Menos de .010 segundos, el resultado en (kW) sería lo mismo que el de .010 segundos.

Nominal anode input power for the anode heat content 70%. IEC 613/1989

Puissance calorifique nominale de l'anode: 70%, CEI 613/1989

Thermische Anoden bezugsleistung für eine speicherung von 70%. IEC 613/1989

Aproximadamente el Poder de Penetración Para Obtener Unalmacenaje de Calor Del Anodo de 70%. IEC 613/1989

0.6 Focal Spot 3Ø 12 Degrees 150/180 Hz  
0.6 Dimension Focale 3Ø 12 Degrés 150/180 Hz  
0.6 Brennpunkt 3Ø 12 Grad 150/180 Hz  
0.6 De Marcas Focales 3Ø 12 Grados 150/180 Hz

Caractéristiques Pour L'Angiographie CEI 613/1989  
Angiographische Nennleistungen IEC 613/1989  
Gradaciones Angiografica IEC 613/1989

Exposure rate per second	Tube load (kW) as a function of the exposure time (seconds) of the individual radiographs of the series															Number of exposures in series
	0.010	0.020	0.030	0.040	0.050	0.060	0.080	0.100	0.120	0.140	0.160	0.180	0.200	0.225	0.250	
1	36.4	34.8	33.5	32.5	31.5	30.7	29.2	27.9	26.8	25.8	24.8	24.0	23.2	22.3	21.5	10
2	36.1	34.3	32.9	31.7	30.6	29.6	27.9	26.5	25.2	24.0	23.0	22.1	21.3	20.3	19.4	
3	36.0	34.0	32.4	31.1	30.0	28.9	27.1	25.5	24.2	23.0	21.9	20.9				
4	35.8	33.8	32.1	30.7	29.5	28.4	26.5	24.9	23.5	22.2						
8	35.4	33.1	31.2	29.6	28.2	27.0										
15	34.9	32.2	30.1	28.3												
30	34.2	31.0														
1	36.0	34.1	32.6	31.3	30.1	29.1	27.3	25.8	24.4	23.2	22.2	21.2	20.4	19.4	18.5	20
2	35.6	33.4	31.6	30.2	28.8	27.7	25.6	23.9	22.5	21.2	20.1	19.1	18.2	17.2	16.3	
3	35.3	32.9	31.0	29.3	27.9	26.6	24.5	22.7	21.1	19.8	18.7	17.7				
4	35.1	32.5	30.4	28.7	27.2	25.8	23.6	21.7	20.2	18.8						
8	34.4	31.4	29.0	27.0	25.3	23.8										
15	33.7	30.2	27.5	25.3												
30	32.7	28.6														
1	35.4	32.9	31.0	29.4	28.0	26.7	24.6	22.8	21.3	20.0	18.8	17.8	16.9	15.9	15.0	40
2	34.9	32.1	29.9	28.1	26.5	25.2	22.8	20.9	19.4	18.0	16.8	15.8	14.9	14.0	13.1	
3	34.5	31.4	29.1	27.1	25.4	24.0	21.5	19.6	18.0	16.6	15.5	14.5				
4	34.1	30.9	28.4	26.3	24.5	23.0	20.5	18.5	16.9	15.6						
8	33.1	29.2	26.3	24.0	22.1	20.4										
15	32.0	27.6	24.3	21.8												
30	30.6	25.6														
1	34.8	32.0	29.7	27.9	26.3	24.9	22.5	20.6	19.0	17.7	15.6	13.9	12.5	11.1	10.0	60
2	34.3	31.1	28.6	26.6	24.8	23.3	20.9	18.9	17.3	15.9	14.8	13.8	12.5	11.1	10.0	
3	33.8	30.3	27.7	25.5	23.7	22.1	19.6	17.6	16.0	14.7	13.5	12.6				
4	33.4	29.7	26.9	24.6	22.8	21.2	18.6	16.6	15.0	13.7						
8	32.2	27.9	24.7	22.2	20.2	18.5										
15	30.8	25.8	22.3	19.7												
30	29.1	23.6														
1	34.3	31.1	28.6	26.5	24.8	23.3	20.8	18.8	15.6	13.4	11.7	10.4	9.4	8.3	7.5	80
2	33.7	30.2	27.4	25.2	23.4	21.8	19.3	17.3	15.6	13.4	11.7	10.4	9.4	8.3	7.5	
3	33.2	29.4	26.5	24.2	22.3	20.7	18.1	16.1	14.5	13.2	11.7	10.4				
4	32.8	28.8	25.7	23.3	21.4	19.7	17.2	15.2	13.6	12.4						
8	31.5	26.8	23.4	20.8	18.8	17.1										
15	29.9	24.6	20.9	18.3												
30	27.9	22.0														
1	33.7	30.2	27.5	25.4	23.5	22.0	18.8	15.0	12.5	10.7	9.4	8.3	7.5	6.7	6.0	100
2	33.2	29.3	26.4	24.1	22.2	20.6	18.0	15.0	12.5	10.7	9.4	8.3	7.5	6.7	6.0	
3	32.7	28.6	25.5	23.1	21.1	19.5	16.9	14.9	12.5	10.7	9.4	8.3				
4	32.2	27.9	24.7	22.2	20.2	18.6	16.0	14.0	12.5	10.7						
8	30.8	25.9	22.4	19.8	17.7	16.1										
15	29.1	23.6	19.9	17.2												
30	26.9	20.8														
1	32.6	28.4	25.3	22.8	20.0	16.7	12.5	10.0	8.3	7.1	6.2	5.6	5.0	4.4	4.0	150
2	32.0	27.5	24.2	21.7	19.7	16.7	12.5	10.0	8.3	7.1	6.2	5.6	5.0	4.4	4.0	
3	31.5	26.7	23.4	20.8	18.8	16.7	12.5	10.0	8.3	7.1	6.2	5.6				
4	31.0	26.1	22.6	20.0	18.0	16.3	12.5	10.0	8.3	7.1						
8	29.5	24.1	20.4	17.7	15.7	14.1										
15	27.7	21.7	17.9	15.3												
30	25.1	18.7														

**Note:**

1. (kW) of Exposure Equals mA x kV.  
For Example: 70 kV x 300 mA = 21 kW.  
2. Exposures less than .010 seconds will have a kW rating same as .010 seconds.

**Remarque:**

1. (kW) en exposition égale kV x mA.  
Par exemple: 70 kV x 300 mA = 21 kW.  
2. Les expositions inférieures à 0.010 sec. ont les mêmes valeurs en kW que celles de 0.010 sec.

**Anmerkungen:**

1. (kW) der Belichtung ist gleich mA x kV.  
Zum Beispiel: 70 kV x 300 mA = 21 kW.  
2. Belichtungen von weniger als .010 Sekunden haben die gleichen kW Werte wie die von .010 Sekunden.

**Nota:**

1. (kW) De exposición se calcula multiplicando mA x kV-porejemplo: 70 kV x 300 mA = 21 kW.  
2. Para Exposiciones de Menos de .010 segundos, el resultado en (kW) sería lo mismo que el de .010 segundos.

Nominal anode input power for the anode heat content 70%. IEC 613/1989

Puissance calorifique nominale de l'anode: 70%, CEI 613/1989

Thermische Anoden bezugsleistung für eine speicherung von 70%. IEC 613/1989

Aproximadamente el Poder de Penetracion Para Obtener Unalmacenaje de Calor Del Anode de 70%. IEC 613/1989

1.2 Focal Spot 3Ø 12 Degrees 150/180 Hz  
1.2 Dimension Focale 3Ø 12 Degrés 150/180 Hz  
1.2 Brennpunkt 3Ø 12 Grad 150/180 Hz  
1.2 De Marcas Focales 3Ø 12 Grados 150/180 Hz

Caractéristiques Pour L'Angiographie CEI 613/1989  
Angiographische Nennleistungen IEC 613/1989  
Gradaciones Angiografica IEC 613/1989

Exposure rate per second	Tube load (kW) as a function of the exposure time (seconds) of the individual radiographs of the series															Number of exposures in series
	0.010	0.020	0.030	0.040	0.050	0.060	0.080	0.100	0.120	0.140	0.160	0.180	0.200	0.225	0.250	
1	94.9	88.3	83.3	79.1	75.5	72.4	67.0	62.5	58.6	55.3	52.4	49.8	47.4	44.8	42.5	10
2	94.1	87.0	81.7	77.2	73.3	69.9	64.2	59.5	55.5	52.1	49.1	46.4	44.1	41.5	39.2	
3	93.6	86.1	80.4	75.7	71.7	68.2	62.3	57.4	53.3	49.8	46.8	44.2				
4	93.1	85.4	79.5	74.6	70.4	66.8	60.7	55.7	51.6	48.1						
8	91.8	83.1	76.5	71.2	66.7	62.8										
30	90.1	80.4	73.2	67.3												
1	92.2	83.8	77.5	72.2	67.8	64.0	57.7	52.6	48.4	44.8	41.8	39.2	36.9	33.3	30.0	20
2	91.0	81.9	75.0	69.5	64.8	60.8	54.2	49.0	44.8	41.2	38.2	35.7	33.4	31.0	29.0	
3	90.3	80.6	73.4	67.6	62.8	58.7	52.0	46.8	42.6	39.1	36.1	33.6				
4	89.6	79.6	72.1	66.2	61.3	57.1	50.3	45.1	40.9	37.4						
8	87.6	76.5	68.4	62.1	56.9	52.6										
30	85.3	73.0	64.3	57.6												
1	88.1	77.3	69.3	63.0	57.9	53.6	46.8	37.5	31.2	26.8	23.4	20.8	18.8	16.7	15.0	40
2	86.3	74.6	66.1	59.5	54.2	49.9	43.0	37.5	31.2	26.8	23.4	20.8	18.8	16.7	15.0	
3	85.1	72.7	64.0	57.2	51.9	47.5	40.6	35.6	31.2	26.8	23.4	20.8				
4	84.2	71.4	62.4	55.6	50.2	45.8	39.0	34.0	30.2	26.8						
8	81.6	67.8	58.3	51.3	45.9	41.5										
30	78.5	63.6	53.8	46.7												
1	84.6	72.1	63.2	56.4	50.0	41.7	31.2	25.0	20.8	17.9	15.6	13.9	12.5	11.1	10.0	60
2	82.6	69.2	59.9	53.0	47.5	41.7	31.2	25.0	20.8	17.9	15.6	13.9	12.5	11.1	10.0	
3	81.1	67.1	57.6	50.6	45.1	40.8	31.2	25.0	20.8	17.9	15.6	13.9				
4	79.9	65.5	55.8	48.8	43.3	39.0	31.2	25.0	20.8	17.9						
8	76.9	61.6	51.6	44.5	39.2	35.0										
30	73.5	57.3	47.2	40.2												
1	81.5	67.7	58.2	46.9	37.5	31.2	23.4	18.8	15.6	13.4	11.7	10.4	9.4	8.3	7.5	80
2	79.4	64.8	55.1	46.9	37.5	31.2	23.4	18.8	15.6	13.4	11.7	10.4	9.4	8.3	7.5	
3	77.8	62.7	52.8	45.7	37.5	31.2	23.4	18.8	15.6	13.4	11.7	10.4				
4	76.5	61.0	51.0	43.9	37.5	31.2	23.4	18.8	15.6	13.4						
8	73.0	56.7	46.6	39.6	34.5	30.6										
30	69.5	52.5	42.4	35.7												
1	78.7	63.9	50.0	37.5	30.0	25.0	18.8	15.0	12.5	10.7	9.4	8.3	7.5	6.7	6.0	100
2	76.5	61.1	50.0	37.5	30.0	25.0	18.8	15.0	12.5	10.7	9.4	8.3	7.5	6.7	6.0	
3	74.9	59.0	48.9	37.5	30.0	25.0	18.8	15.0	12.5	10.7	9.4	8.3				
4	73.5	57.3	47.2	37.5	30.0	25.0	18.8	15.0	12.5	10.7						
8	69.7	52.8	42.7	35.9	30.0	25.0										
30	66.0	48.7	38.7	32.2												
1	72.5	50.0	33.3	25.0	20.0	16.7	12.5	10.0	8.3	7.1	6.2	5.6	5.0	4.4	4.0	150
2	70.4	50.0	33.3	25.0	20.0	16.7	12.5	10.0	8.3	7.1	6.2	5.6	5.0	4.4	4.0	
3	68.7	50.0	33.3	25.0	20.0	16.7	12.5	10.0	8.3	7.1	6.2	5.6				
4	67.3	50.0	33.3	25.0	20.0	16.7	12.5	10.0	8.3	7.1						
8	63.3	45.8	33.3	25.0	20.0	16.7										
30	59.2	41.6	32.2	25.0												

**Note:**  
1. (kW) of Exposure Equals mA x kV.  
For Example: 70 kV x 300 mA = 21 kW.  
2. Exposures less than .010 seconds will have a kW rating same as .010 seconds.

**Remarque:**  
1. (kW) en exposition égale kV x mA.  
Par exemple: 70 kV x 300 mA = 21 kW.  
2. Les expositions inférieures à 0.010 sec. ont les mêmes valeurs en kW que celles de 0.010 sec.

**Anmerkungen:**  
1. (kW) der Belichtung ist gleich mA x kV.  
Zum Beispiel: 70 kV x 300 mA = 21 kW.  
2. Belichtungen von weniger als .010 Sekunden haben die gleichen kW Werte wie die von .010 Sekunden.

**Nota:**  
1. (kW) De exposición se calcula multiplicando mA x kV-porejemplo: 70 kV x 300 mA = 21 kW.  
2. Para Exposiciones de Menos de .010 segundos, el resultado en (kW) sería lo mismo que el de .010 segundos.

Nominal anode input power for the anode heat content 70%. IEC 613/1989

Puissance calorifique nominale de l'anode: 70%, CEI 613/1989

Thermische Anoden bezugsleistung für eine speicherung von 70%. IEC 613/1989

Aproximadamente el Poder de Penetracion Para Obtener Unalmacenaje de Calor Del Anode de 70%. IEC 613/1989

**3 Ø FULL WAVE**

Abaques d' Émissions des Filaments CEI 613/1989  
Heizfadenemissionsdiagramm IEC 613/1989  
Curvas de Emisión de los Filamentos IEC 613/1989

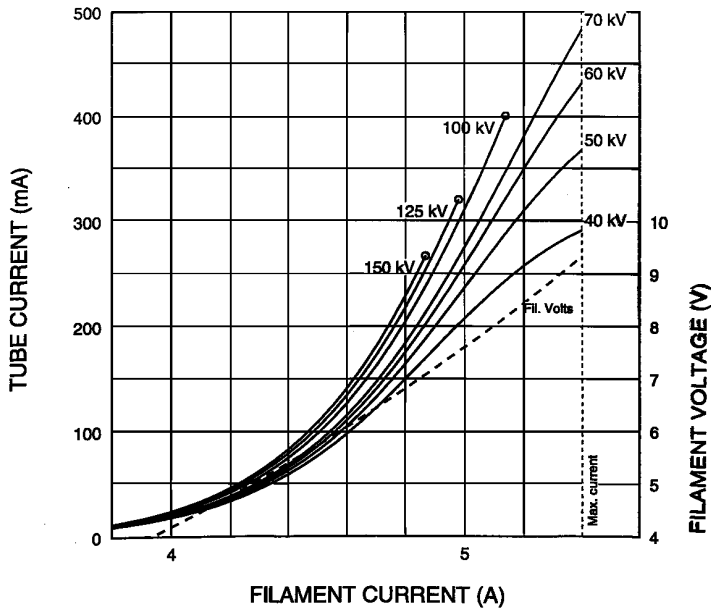

THREE PHASE EMISSION ( $\pm .15$  A)  
G292                      0.6                     

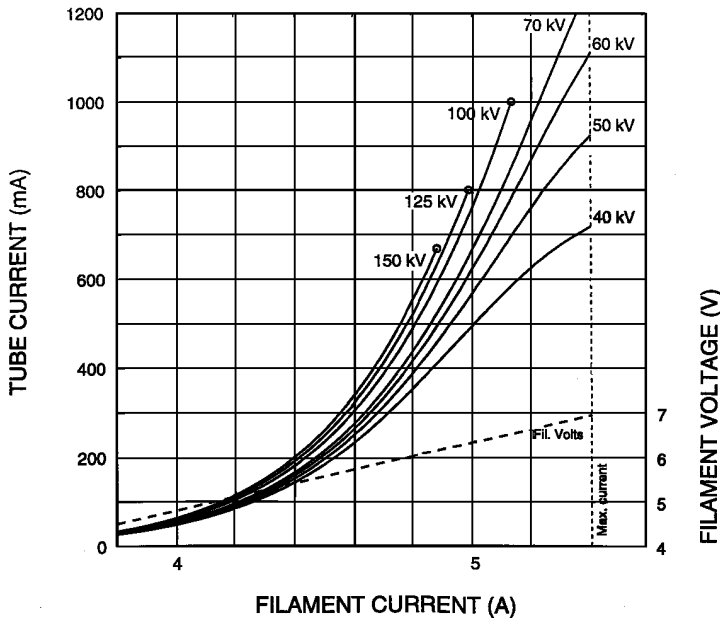

THREE PHASE EMISSION ( $\pm .15$  A)  
G292                      1.2                     

Note:	When using these emission curves for trial exposures, refer to the power rating curves shown for maximum kV, tube emission, filament current, exposure time, and target speed.
Remarque:	Lors de l'utilisation de ces abaques pour des expositions d'essai, référez-vous aux courbes maximales de kV, d'émission du filament, de temps d'exposition et de vitesse de rotation.
Anmerkung:	Wenn Sie diese Emissionskurven für Testaufnahmen verwenden, beziehen Sie sich hierbei auf die entsprechenden Nennleistungskurven für max. kV-Werte, Röhrenemission, Heizstrom, und Anodendrehzahl.
Nota:	Si utiliza estas curvas de emisión para exposiciones de prueba, refiérase a las curvas de gradación de potencia para el máximo de kV, tubo de emisión, corriente en los filamentos, tiempo de exposición, y a las curvas de velocidad del objetivo.

Abaques d' Échauffement et de Refroidissement de L'Anode  
Anoden Aufheiz - und Abkühl Kurven  
Curvas de Calentamiento y Enfriamiento del Anodo

